

# AGIES



## Automation systems for road barriers



**Atlas Group**  
**868 Plymouth Road**  
**Slough Trading Estate**  
**Slough**  
**Berkshire SL1 4LP**  
**Tel: 01753 696166**  
**Fax: 01753 696916**  
**Email: info@atlasgroup.co.uk**  
**Web: www.atlasgroup.co.uk**

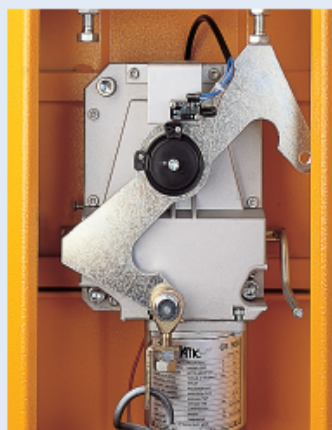

Manual release device

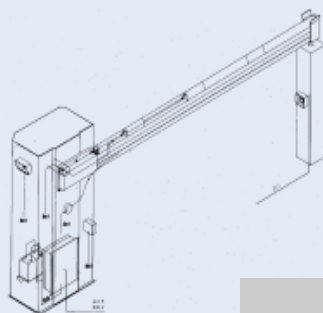

### Operating limits

CS 250: 2,5 mt.  
 CS 500: 2 - 5 mt.  
 CS 650: 4 - 6,50 mt.

### ELECTROMECHANICAL IRREVERSIBLE GEARMOTORS

- adjustable speed
- built-in control board
- 24 V d.c.
- slow-down device when closing/opening
- continuous use
- detection of the obstacle and reopening with amperometric device
- CS 500 model is designed to control roads up to 5 mt.
- may be equipped with emergency batteries

Dati Tecnici	Technical Data	CS 250	CS 500	CS 650
Alimentazione	Power supply	V.A.C. 230	V.A.C. 230	V.A.C. 230
Alimentazione motore	Motor feed	V.D.C. 24	V.D.C. 24	V.D.C. 24
Potenza motore	Motor power	W 70	W 80	W 80
Assorbimento motore	Absorbed current	A 4,5	A 4,6	A 4,6
Coppia all'albero	Shaft torque	Nm 100	Nm 210	Nm 290
Frequenza lavoro	Operating frequency	*	*	*
Rapporto riduzione	Gearing-down ratio	0,005	0,005	0,005
Grado di protezione	Degree of protection	IP 54	IP 54	IP 54
Classe isolamento	Class of insulation	Y	Y	Y
Temp. funzionamento	Operating temperature	-20°/+70 °C	-20°/+70 °C	-20°/+70 °C
Tempo apertura	Opening time	sec 2,5	sec 6	sec 8
Lubrificazione	Lubrication	**	grasso**/grease	
Peso	Weight	Kg 40	Kg 61	Kg 105
Dimensioni	Dimensions	mm 250x200	mm 320x320	mm 450x250
		H1000	H1060	H1075



## ACCESSORIES



CE.AF Moveable rod support  
CE.AM Fixed beam support



CESA Fixed support with Electric lock



Warning lamps



CSN Beam articulated joint



C3M Set springs for CS500/CS650



Joint for AL500 beam  
CRB2 joint for AL650 beam



VEK M1H Loop detector



Red & green traffic lights



CEDAGET Token machine with column and anchor base